

# Ramping Data

Straight ramping

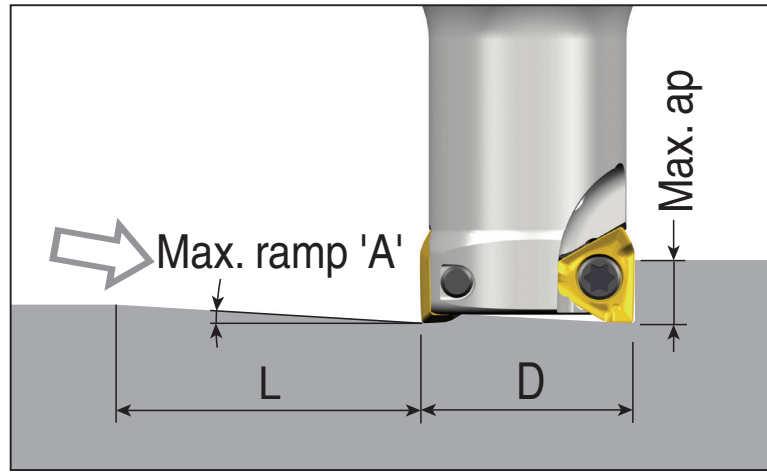

Helical ramping

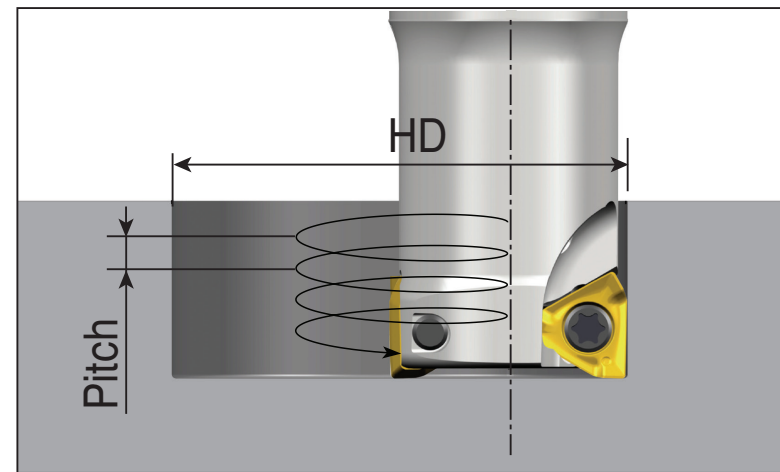

## 3PKT 04

(unit: mm)

Cutter dia.(D)	Straight ramp down			Helical ramp down		
	Max. ramp (A°)	Max. ap	Min. length (L)	Min. dia.(HD)	Max. dia.(HD)	Max. pitch/rev.
Ø8	2.1	3.5	95	13.2		0.6
					16	0.9
Ø10	2.2	3.5	91	17.2		0.8
					20	1.2
Ø11	3.6	3.5	56	19.2		1.6
					22	2.1
Ø12	3.3	3.5	61	21.2		1.6
					24	2.1
Ø13	2.5	3.5	80	23.2		1.4
					26	1.7
Ø14	2.2	3.5	91	25.2		1.3
					28	1.6
Ø16	1.6	3.5	125	29.2		1.1
					32	1.4