

Ramping Data

Straight ramping

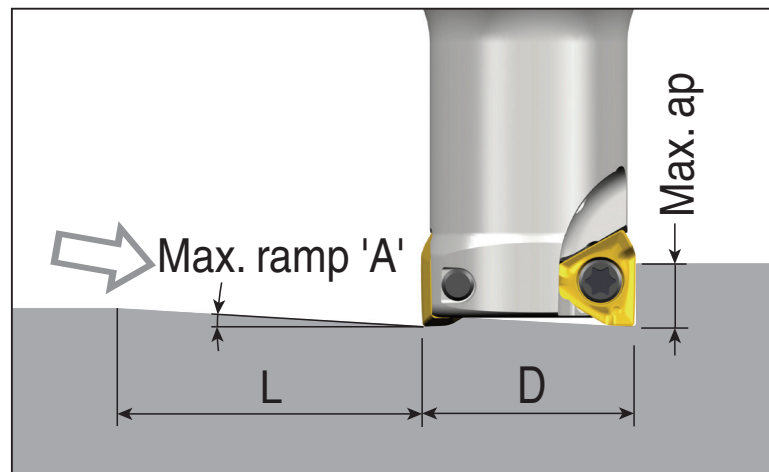

Helical ramping

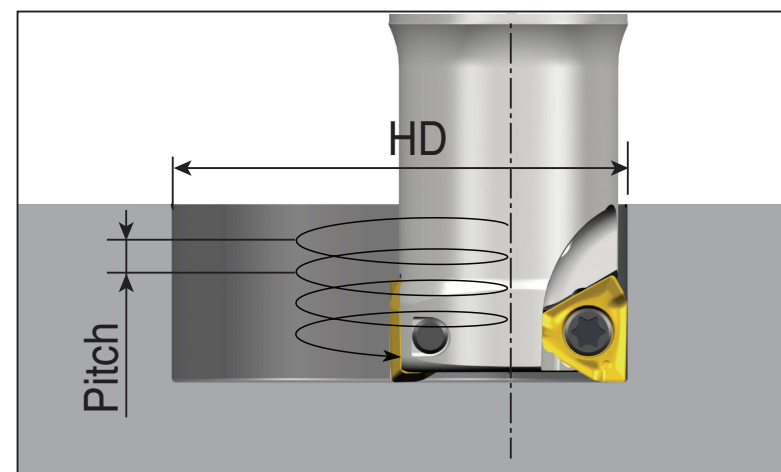

3PK(H)T 06

(unit: mm)

Cutter dia.(D)	Straight ramp down			Helical ramp down		
	Max. ramp (A°)	Max. ap	Min. length (L)	Min. dia.(HD)	Max. dia.(HD)	Max. pitch/rev.
Ø12	3.7	4.7	73	19.5		1.3
					24	2.1
Ø14	2.8	4.7	96	23.5		1.2
					28	1.8
Ø16	2.3	4.7	117	27.5		1.2
					32	1.7
Ø17	2.0	4.7	135	29.5		1.2
					34	1.6
Ø18	2.0	4.7	135	31.5		1.3
					36	1.7
Ø20	1.6	4.7	168	35.5		1.2
					40	1.5
Ø21	1.5	4.7	180	37.5		1.2
					42	1.5
Ø22	1.5	4.7	180	39.5		1.2
					44	1.5
Ø25	1.5	4.7	180	45.5		1.4
					50	1.7
Ø30	1.2	4.7	224	55.5		1.4
					60	1.7
Ø32	1.2	4.7	224	59.5		1.5
					64	1.8
Ø35	1.0	4.7	269	65.5		1.4
					70	1.6
Ø40	0.7	4.7	385	75.5		1.2
					80	1.3