

Ramping Data

Straight ramping

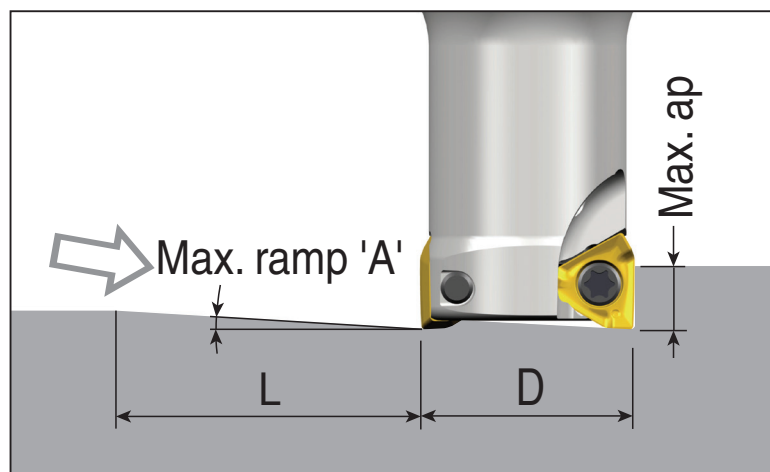

Helical ramping

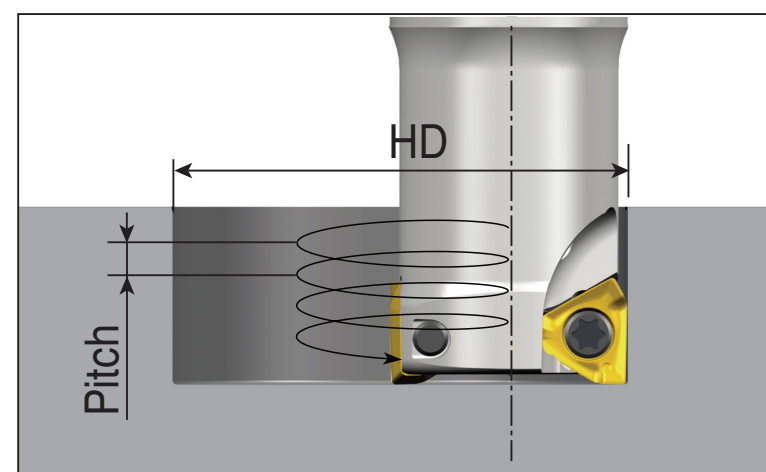

3PK(H)T 10

(unit: mm)

Cutter dia.(D)	Straight ramp down			Helical ramp down		
	Max. ramp (A°)	Max. ap	Min. length (L)	Min. dia.(HD)	Max. dia.(HD)	Max. pitch/rev.
Ø16	7.0	7.0	57	24.7		2.8
					32	5.2
Ø20	3.3	7.0	121	33.9		2.1
					40	3.1
Ø21	3.2	7.0	125	35.9		2.2
					42	3.1
Ø22	3.2	7.0	125	37.9		2.4
					44	3.3
Ø25	2.8	7.0	143	43.5		2.4
					50	3.3
Ø26	2.6	7.0	154	45.9		2.4
					52	3.1
Ø30	2.0	7.0	201	53.9		2.2
					60	2.8
Ø32	1.8	7.0	223	57.5		2.1
					64	2.7
Ø33	1.7	7.0	236	59.9		2.1
					66	2.6
Ø40	1.3	7.0	309	73.7		2.0
					80	2.4
Ø50	1.0	7.0	401	93.7		2.0
					100	2.3
Ø63	0.8	7.0	502	119.7		2.1
					126	2.3