

Ramping Data

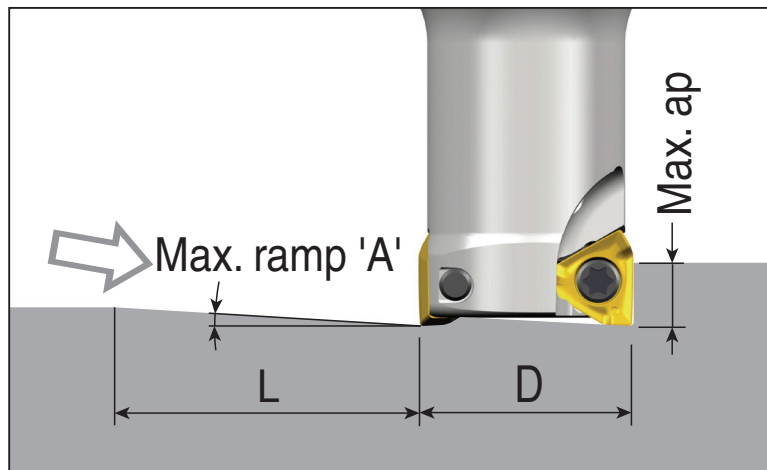

Straight ramping



Helical ramping

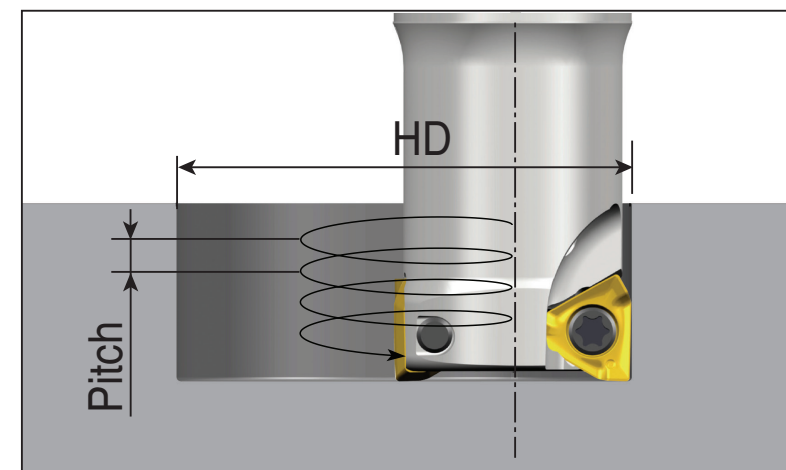

3PK(H)T 15

(unit: mm)

Cutter dia.(D)	Straight ramp down			Helical ramp down		
	Max. ramp (A°)	Max. ap	Min. length (L)	Min. dia.(HD)	Max. dia.(HD)	Max. pitch/rev.
Ø32	3.2	11.0	197	53.5		3.2
					64	4.8
Ø33	3.1	11.0	203	55.5		3.3
					66	4.8
Ø35	3.1	11.0	203	59.5		3.5
					70	5.1
Ø40	2.0	11.0	315	70.1		2.8
					80	3.7
Ø50	1.5	11.0	420	90.1		2.8
					100	3.5
Ø63	1.1	11.0	573	116.1		2.7
					126	3.2
Ø80	0.8	11.0	788	150.3		2.6
					160	3.0
Ø100	0.6	11.0	1051	190.5		2.5
					200	2.8
Ø125	0.5	11.0	1261	240.3		2.7
					250	2.9
Ø160	0.3	11.0	2102	310.3		2.1
					320	2.2
Ø200	0.2	11.0	3153	390.3		1.8
					400	1.9