

Ramping Data

Straight ramping

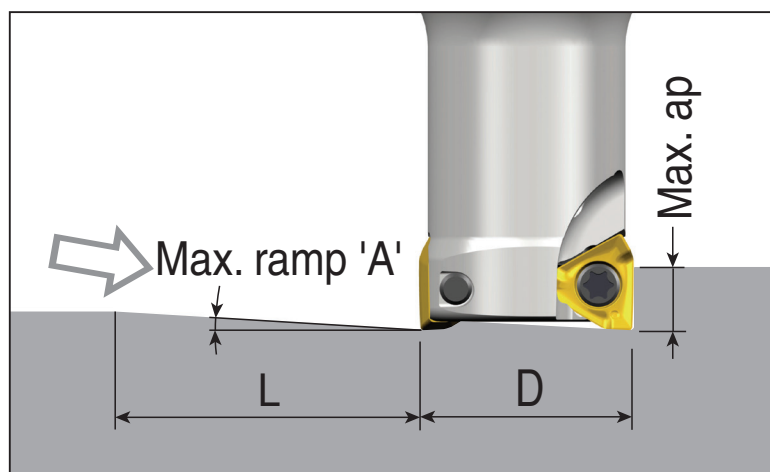

Helical ramping

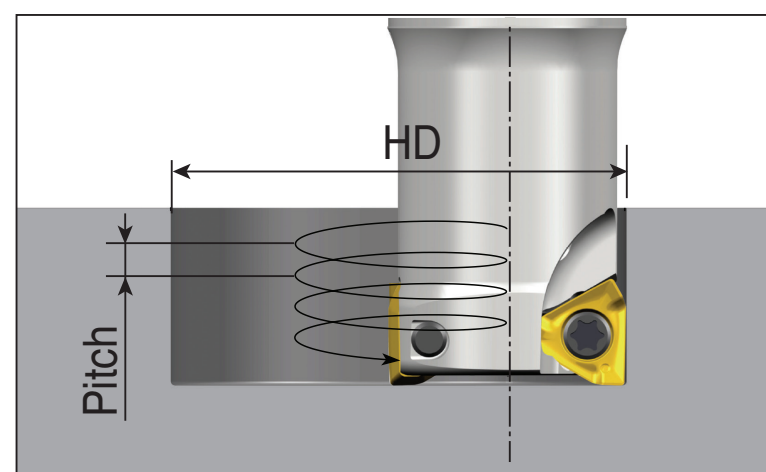

3PK(H)T 19

(unit: mm)

Cutter dia.(D)	Straight ramp down			Helical ramp down		
	Max. ramp (A°)	Max. ap	Min. length (L)	Min. dia.(HD)	Max. dia.(HD)	Max. pitch/rev.
Ø40	3.6	15.0	239	66.7		4.5
					80	6.7
Ø50	2.2	15.0	391	87.9		3.9
					100	5.1
Ø63	1.7	15.0	506	113.9		4
					126	5
Ø80	1.3	15.0	661	147.9		4.1
					160	4.8
Ø100	1.0	15.0	860	187.9		4.1
					200	4.7
Ø125	0.8	15.0	1075	237.9		4.2
					250	4.7
Ø160	0.6	15.0	1433	307.9		4.1
					320	4.5
Ø200	0.4	15.0	2150	387.9		3.5
					400	3.7
Ø250	0.3	15.0	2866	487.9		3.3
					500	3.5