

# Ramping Data



Straight ramping

Helical ramping

Step down

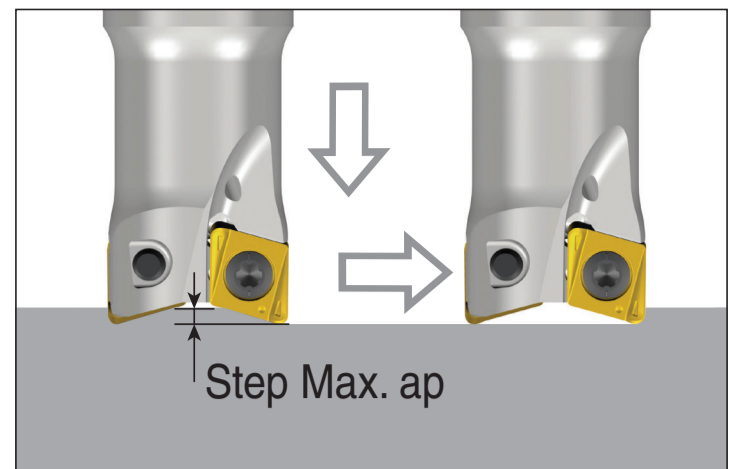
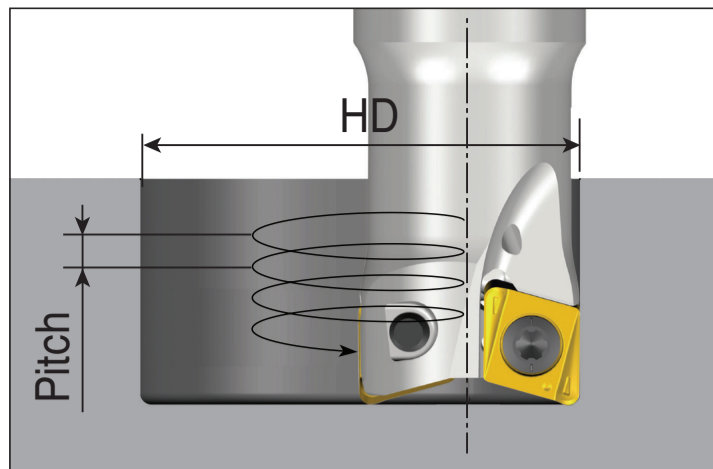
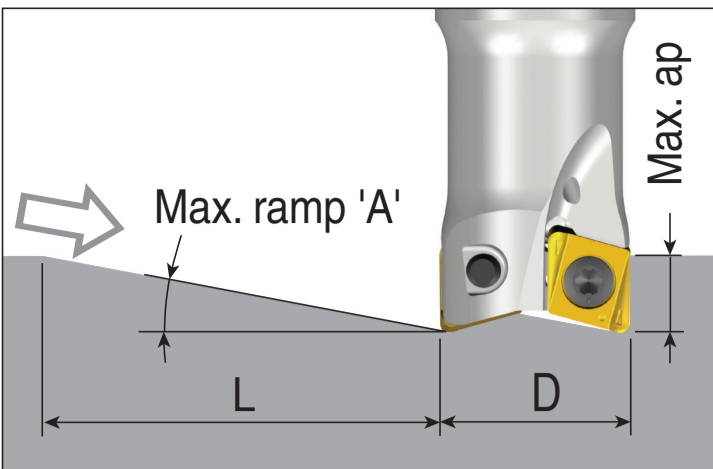

## 4NKT 09: R0.8

(unit: mm)

Cutter dia.(D)	Straight ramp down			Helical ramp down			Step down
	Max. ramp (A°)	Max. ap	Min. length (L)	Min. dia.(HD)	Max. dia.(HD)	Max. pitch/rev.	Max. ap
Ø20	3.7	8.0	124	25.5	40	0.9	1.0
Ø25	4.9	8.0	93	35.5	50	2.4	1.6
						5.7	
Ø32	4.9	8.0	93	49.5	64	4.0	2.1
						7.3	
Ø40	3.6	8.0	127	65.5	80	4.3	2.1
						6.7	
Ø50	2.7	8.0	170	85.5	100	4.5	2.1
						6.3	
Ø63	2.0	8.0	224	111.5	126	4.6	2.1
						6.0	
Ø80	1.5	8.0	296	145.5	160	4.7	2.1
						5.8	

## 4NKT 09: R1.6

(unit: mm)

Cutter dia.(D)	Straight ramp down			Helical ramp down			Step down
	Max. ramp (A°)	Max. ap	Min. length (L)	Min. dia.(HD)	Max. dia.(HD)	Max. pitch/rev.	Max. ap
Ø20	2.7	8.0	167	25.5	40	0.7	0.7
						2.6	
Ø25	4.1	8.0	112	35.5	50	2.0	1.3
						4.8	
Ø32	4.4	8.0	104	49.5	64	3.6	1.8
						6.6	
Ø40	3.1	8.0	148	65.5	80	3.7	1.8
						5.8	
Ø50	2.3	8.0	195	85.5	100	3.9	1.8
						5.5	
Ø63	1.8	8.0	255	111.5	126	4.1	1.8
						5.3	
Ø80	1.3	8.0	340	145.5	160	4.1	1.8
						5.0	

## 4NHT 09: R0.4

(unit: mm)

Cutter dia.(D)	Straight ramp down			Helical ramp down			Step down
	Max. ramp (A°)	Max. ap	Min. length (L)	Min. dia.(HD)	Max. dia.(HD)	Max. pitch/rev.	Max. ap
Ø20	2.9	8.0	155	25.5	40	0.8	0.8
						2.7	
Ø25	4.3	8.0	106	35.5	50	2.1	1.3
						5.0	
Ø32	4.5	8.0	102	49.5	64	3.7	1.8
						6.7	
Ø40	3.2	8.0	143	65.5	80	3.8	1.8
						6.0	
Ø50	2.4	8.0	191	85.5	100	4.0	1.8
						5.6	
Ø63	1.8	8.0	255	111.5	126	4.1	1.8
						5.3	
Ø80	1.3	8.0	340	145.5	160	4.1	1.8
						5.0	

## 4NHT 09: R0.8

(unit: mm)

Cutter dia.(D)	Straight ramp down			Helical ramp down			Step down
	Max. ramp (A°)	Max. ap	Min. length (L)	Min. dia.(HD)	Max. dia.(HD)	Max. pitch/rev.	Max. ap
Ø20	2.9	8.0	155	25.5	40	0.8	0.8
						2.7	
Ø25	4.3	8.0	106	35.5	50	2.1	1.3
						5.0	
Ø32	4.5	8.0	102	49.5	64	3.7	1.8
						6.7	
Ø40	3.2	8.0	143	65.5	80	3.8	1.8
						6.0	
Ø50	2.4	8.0	191	85.5	100	4.0	1.8
						5.6	
Ø63	1.8	8.0	255	111.5	126	4.1	1.8
						5.3	
Ø80	1.3	8.0	340	145.5	160	4.1	1.8
						5.0	

Straight ramping

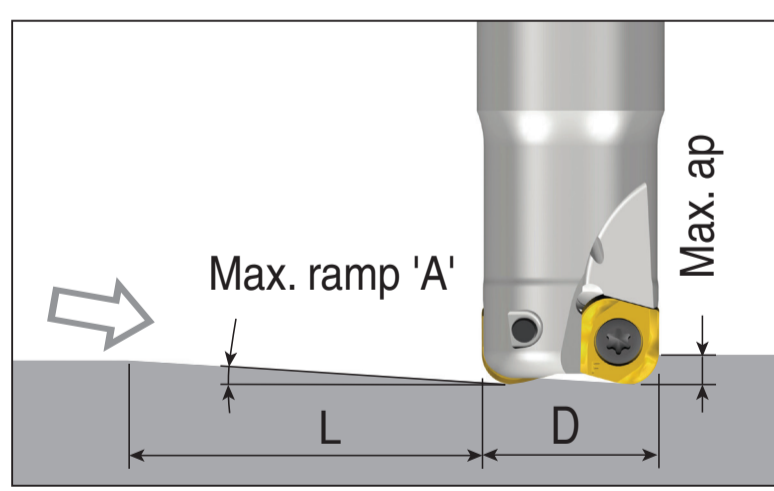

Helical ramping

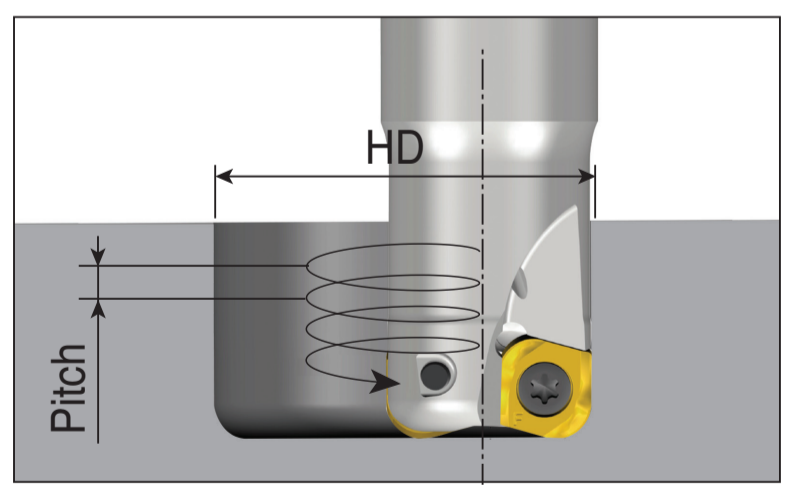

## 4NKT 09-HF: R3.2

(unit: mm)

Cutter dia.(D)	Straight ramp down			Helical ramp down		
	Max. ramp (A°)	Max. ap	Min. length (L)	Min. dia.(HD)	Max. dia.(HD)	Max. pitch/rev.
Ø20	0.3	1.5	287	25	40	0.1
						0.3
Ø25	1.2	1.5	69	35	50	0.6
						1.5
Ø32	2.4	1.5	35	49	64	1.5
						1.5
Ø40	2.3	1.5	37	65	80	1.5
						1.5
Ø50	1.7	1.5	49	85	100	1.5
						1.5
Ø63	1.3	1.5	66	111	126	1.5
						1.5
Ø80	1.0	1.5	86	145	160	1.5
						1.5

## Programming technical data

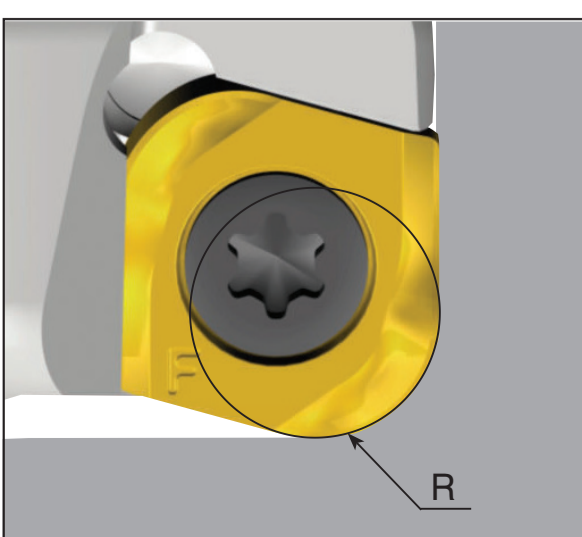

	R Program	A Over cut	B Un-machined
4NKT 090432R-HF	3.2	0	0