

# Ramping Data

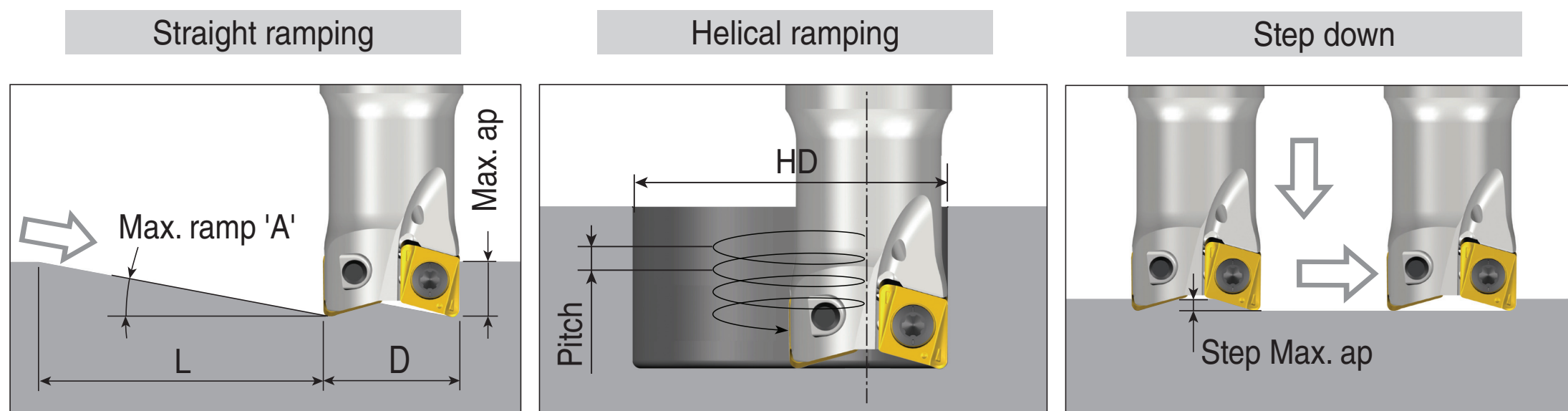

## 4NKT 11: R0.8

(unit: mm)

Cutter dia.(D)	Straight ramp down			Helical ramp down			Step down
	Max. ramp (A°)	Max. ap	Min. length (L)	Min. dia.(HD)	Max. dia.(HD)	Max. pitch/rev.	Max. ap
Ø25	5.1	10.3	115	31.5	50	1.5 6.0	1.7
Ø32	5.3	10.3	111	45.5	64	3.3 7.9	2.4
Ø40	5.0	10.3	118	61.5	80	5.0 9.3	2.7
Ø50	3.7	10.3	159	81.5	100	5.4 8.6	2.7
Ø63	2.7	10.3	219	107.5	126	5.6 7.9	2.7
Ø80	2.0	10.3	288	141.5	160	5.9 7.6	2.7

## 4NKT 11 PNR: R0.8

(unit: mm)

Cutter dia.(D)	Straight ramp down			Helical ramp down			Step down
	Max. ramp (A°)	Max. ap	Min. length (L)	Min. dia.(HD)	Max. dia.(HD)	Max. pitch/rev.	Max. ap
Ø25	4.0	10.3	147	31.5	50	1.2 4.7	1.1
Ø32	4.3	10.3	135	45.5	64	2.7 6.5	1.0
Ø40	4.5	10.3	131	61.5	80	4.5 8.4	0.9
Ø50	3.2	10.3	184	81.5	100	4.7 7.5	0.9
Ø63	2.4	10.3	246	107.5	126	5.0 7.0	0.9
Ø80	1.8	10.3	328	141.5	160	5.2 6.7	0.9

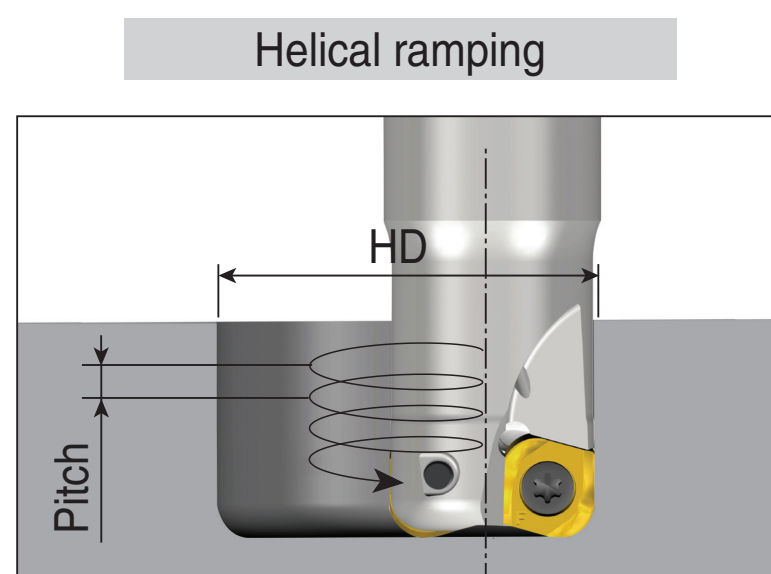
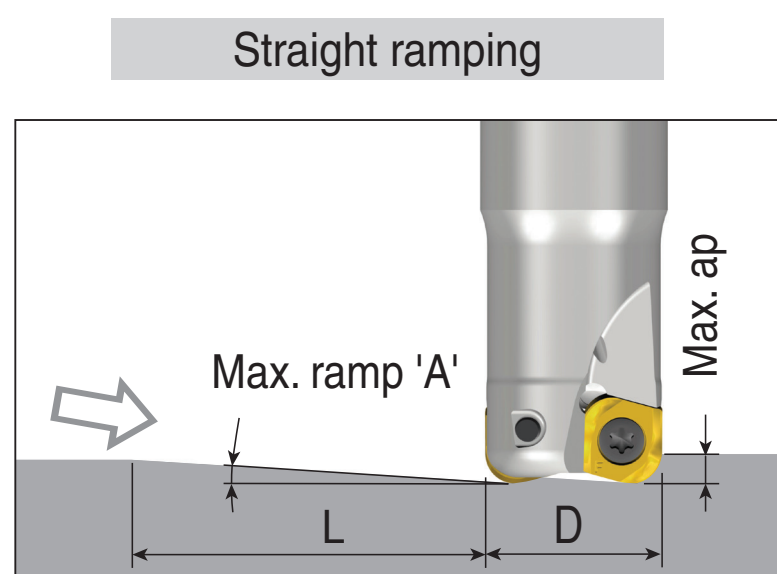

## 4NKT 11-HF: R4.0

(unit: mm)

Cutter dia.(D)	Straight ramp down			Helical ramp down		
	Max. ramp (A°)	Max. ap	Min. length (L)	Min. dia.(HD)	Max. dia.(HD)	Max. pitch/rev.
Ø25	0.8	2.0	143	31	50	0.2 0.9
Ø32	2.0	2.0	57	45	64	1.2 2.0
Ø40	3.4	2.0	34	61	80	2.0 2.0
Ø50	2.4	2.0	48	81	100	2.0 2.0
Ø63	1.8	2.0	64	107	126	2.0 2.0
Ø80	1.3	2.0	85	141	160	2.0 2.0

## Programming technical data

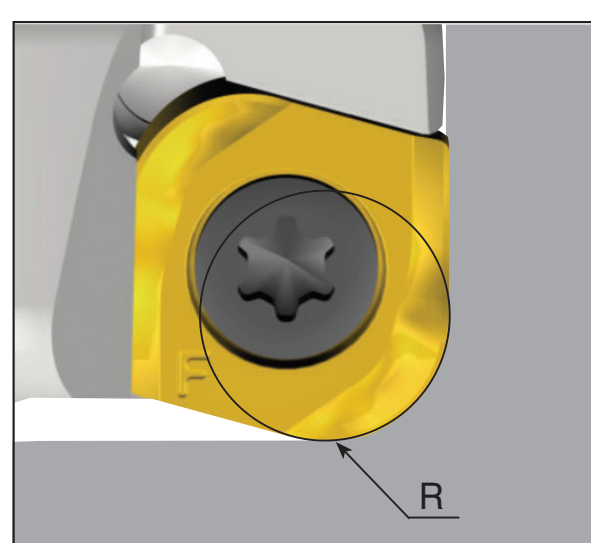

	R Program	A Over cut	B Un-machined
4NKT 110640R-HF	4.0	0	0