

Ramping Data

Straight ramping

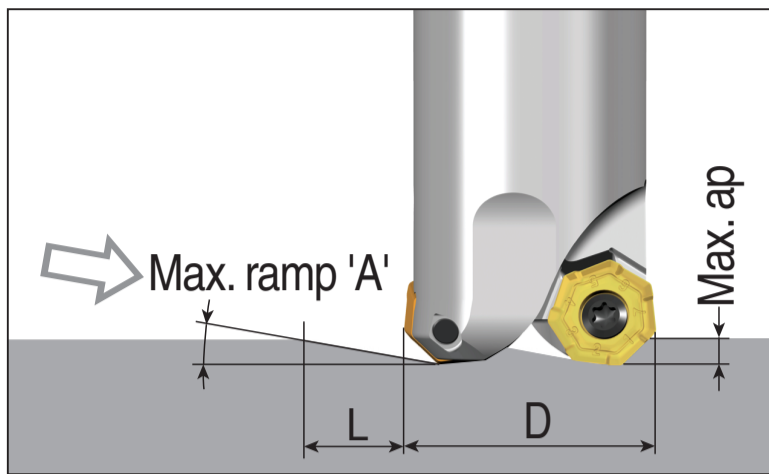

Helical ramping

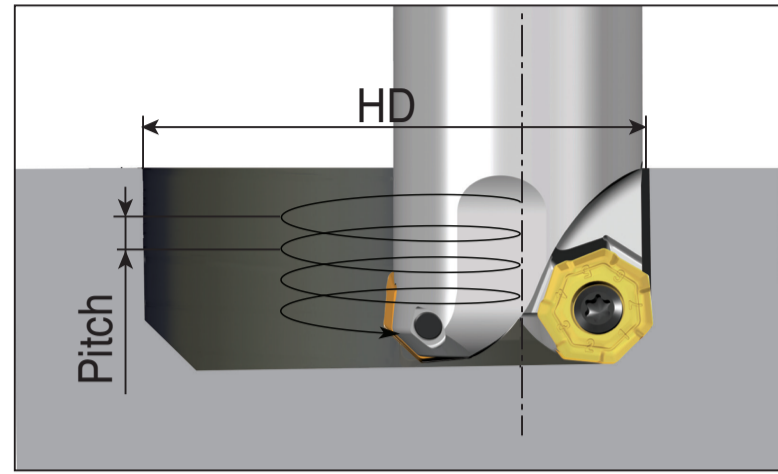

7EMT 06

(unit: mm)

Cutter dia.(D)	Straight ramp down			Helical ramp down		
	Max. ramp (A°)	Max. ap	Min. length (L)	Min. dia.(HD)	Max. dia.(HD)	Max. pitch/rev.
Ø32	29	3.2	6	45.5		3.2
					64	3.2
Ø40	15.5	3.2	12	61.5		3.2
					80	3.2
Ø50	9.5	3.2	19	81.5		3.2
					100	3.2
Ø63	5.5	3.2	33	107.5		3.2
					126	3.2
Ø80	4.0	3.2	46	141.5		3.2
					160	3.2
Ø100	3.0	3.2	61	181.5		3.2
					200	3.2
Ø125	2.0	2.3	66	231.5		3.2
					250	3.2

Programming technical data

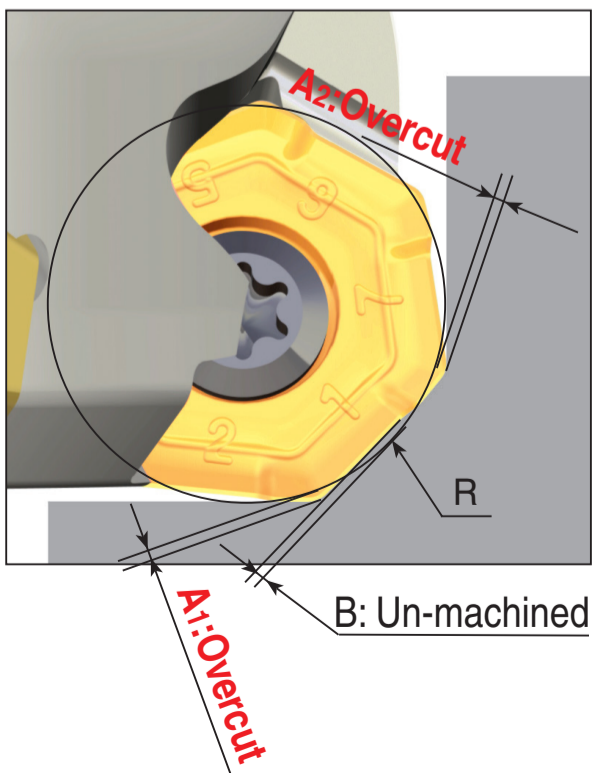

	R Program	A Over cut		B Un-machined
		A1	A2	B
7EMT 06	3	0	0	1.77
	4.5	0	0	1.51
	5	0.03	0.02	0.94
	6	0.21	0.19	0.53

 :Recommended program 'R'