

Ramping Data

Straight ramping

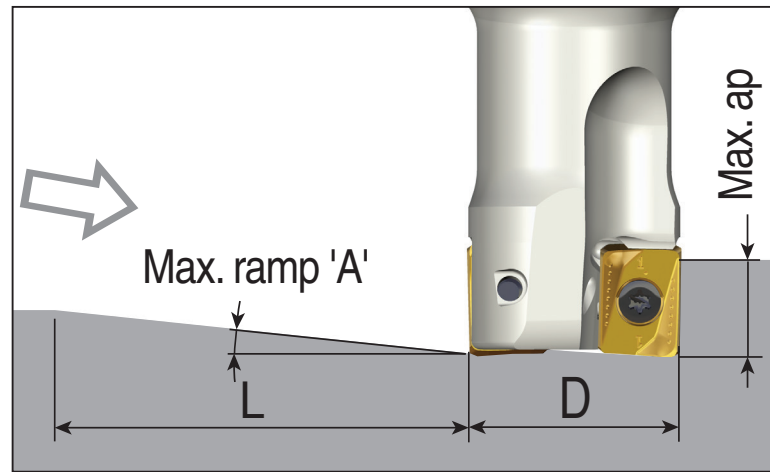

Helical ramping

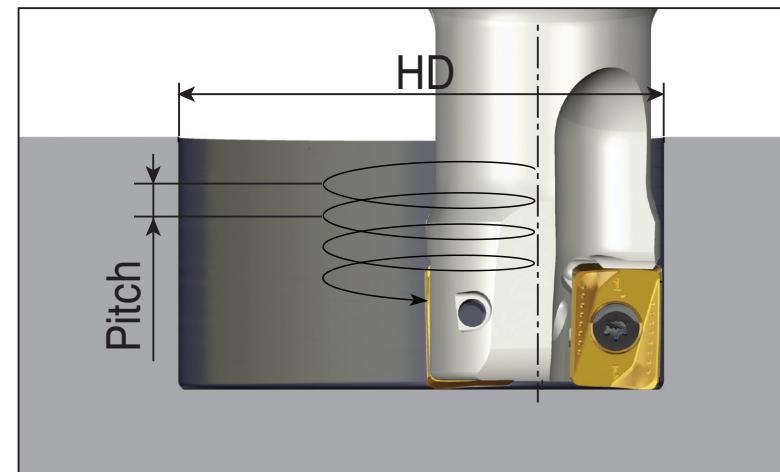

ANH(M)X 11

(unit: mm)

Cutter dia.(D)	Straight ramp down			Helical ramp down		
	Max. ramp (A°)	Max. ap	Min. length (L)	Min. dia.(HD)	Max. dia.(HD)	Max. pitch/rev.
Ø25	1.5	11.0	420	30		0.3
					50	1.7
Ø26	1.4	11.0	450	32		0.4
					52	1.7
Ø32	1.1	11.0	573	44		0.6
					64	1.6
Ø33	1.0	11.0	631	46		0.6
					66	1.5
Ø40	0.8	11.0	788	60		0.7
					80	1.5
Ø50	0.6	11.0	1051	80		0.8
					100	1.4
Ø63	0.4	11.0	1576	106		0.8
					126	1.2
Ø80	0.3	11.0	2102	140		0.8
					160	1.1
Ø100	0.2	11.0	3153	180		0.7
					200	0.9
Ø125	0.2	11.0	3153	230		1.0
					250	1.2