

Ramping Data

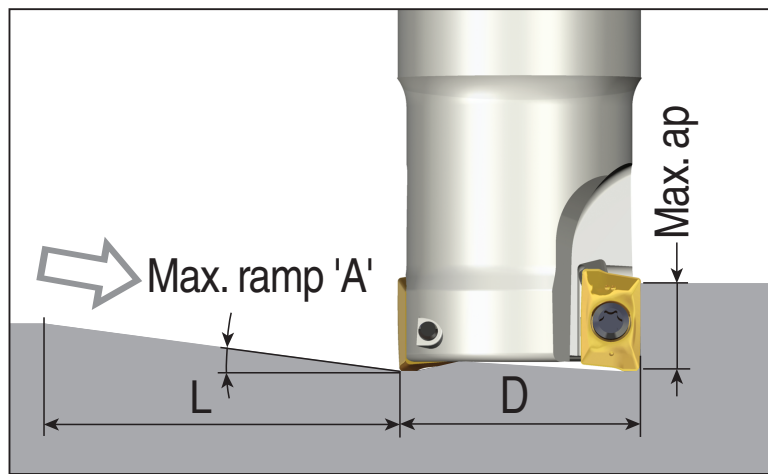

Straight ramping



Helical ramping

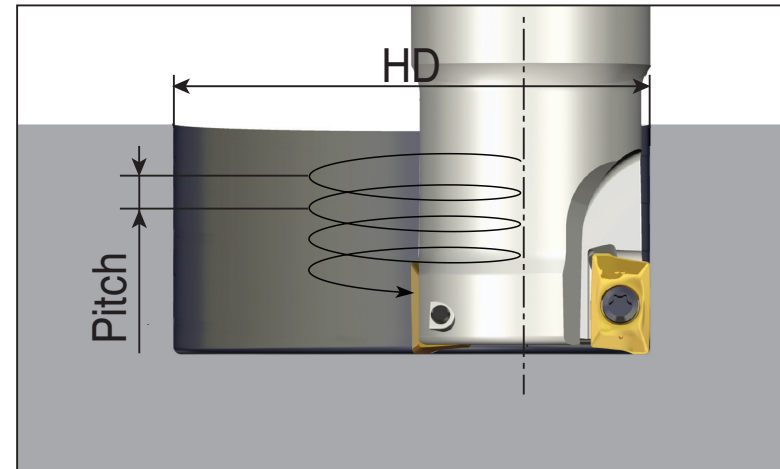

APKT 17

(unit: mm)

| Cutter dia.(D) | Straight ramp down | | | Helical ramp down | | |
|----------------|--------------------|---------|-----------------|-------------------|---------------|-----------------|
| | Max. ramp (A°) | Max. ap | Min. length (L) | Min. dia.(HD) | Max. dia.(HD) | Max. pitch/rev. |
| Ø20 | 8.0 | 16.1 | 115 | 22 | | 0.7 |
| | | | | | 40 | 7.5 |
| Ø25 | 5.0 | 16.1 | 184 | 30.6 | | 1.3 |
| | | | | | 50 | 5.8 |
| Ø26 | 4.0 | 16.1 | 230 | 32.6 | | 1.2 |
| | | | | | 52 | 4.9 |
| Ø32 | 9.0 | 16.1 | 102 | 44.6 | | 5.3 |
| | | | | | 64 | 13.5 |
| Ø33 | 9.0 | 16.1 | 102 | 46.6 | | 5.7 |
| | | | | | 66 | 13.9 |
| Ø40 | 5.0 | 16.1 | 184 | 60.6 | | 4.8 |
| | | | | | 80 | 9.3 |
| Ø50 | 4.4 | 16.1 | 209 | 80.6 | | 6.3 |
| | | | | | 100 | 10.3 |
| Ø63 | 3.2 | 16.1 | 288 | 106.6 | | 6.5 |
| | | | | | 126 | 9.4 |
| Ø80 | 2.3 | 16.1 | 401 | 140.6 | | 6.5 |
| | | | | | 160 | 8.6 |
| Ø100 | 1.8 | 16.1 | 513 | 180.6 | | 6.8 |
| | | | | | 200 | 8.4 |
| Ø125 | 1.4 | 16.1 | 659 | 230.6 | | 6.9 |
| | | | | | 250 | 8.1 |
| Ø160 | 1.0 | 16.1 | 923 | 300.6 | | 6.5 |
| | | | | | 320 | 7.5 |
| Ø200 | 0.7 | 16.1 | 1318 | 380.6 | | 5.9 |
| | | | | | 400 | 6.5 |