

Ramping Data

Straight ramping

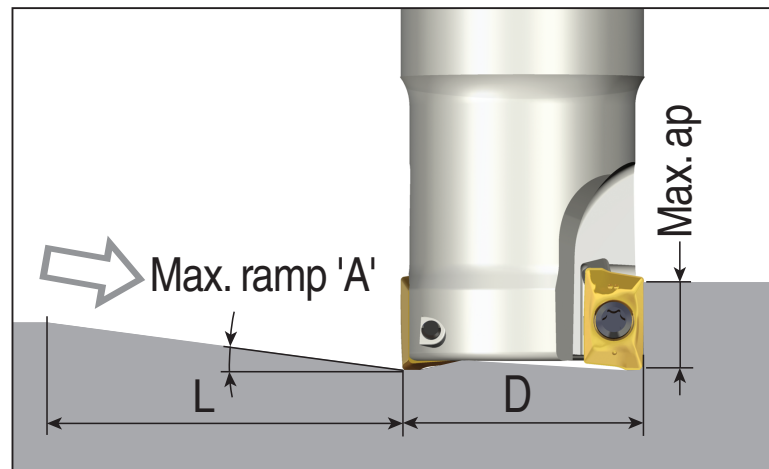

Helical ramping

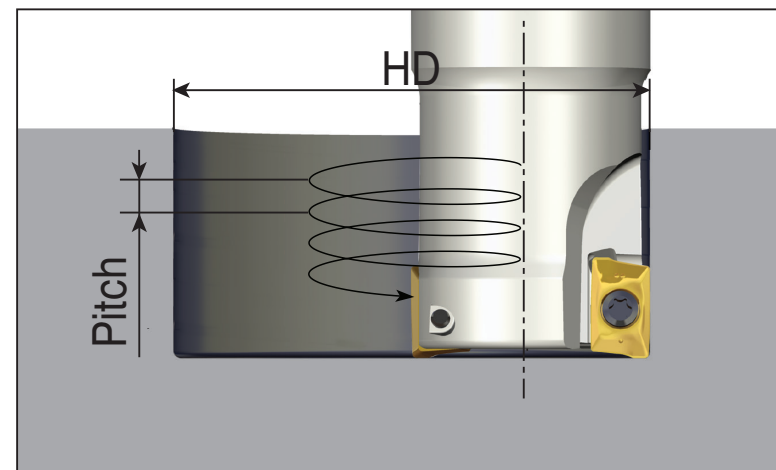

APKT 19

(unit: mm)

Cutter dia.(D)	Straight ramp down			Helical ramp down		
	Max. ramp (A°)	Max. ap	Min. length (L)	Min. dia.(HD)	Max. dia.(HD)	Max. pitch/rev.
Ø40	6.0	17.5	167	56		4.5
					80	11.2
Ø50	4.0	17.5	250	76		4.9
					100	9.3
Ø63	2.9	17.5	346	102		5.3
					126	8.5
Ø80	2.1	17.5	477	136		5.5
					160	7.8
Ø100	1.6	17.5	627	176		5.7
					200	7.5
Ø125	1.2	17.5	736	226		5.6
					250	7.0
Ø160	0.9	17.5	1115	296		5.7
					320	6.7
Ø200	0.7	17.5	1433	376		5.7
					400	6.5