

Ramping Data

Straight ramping

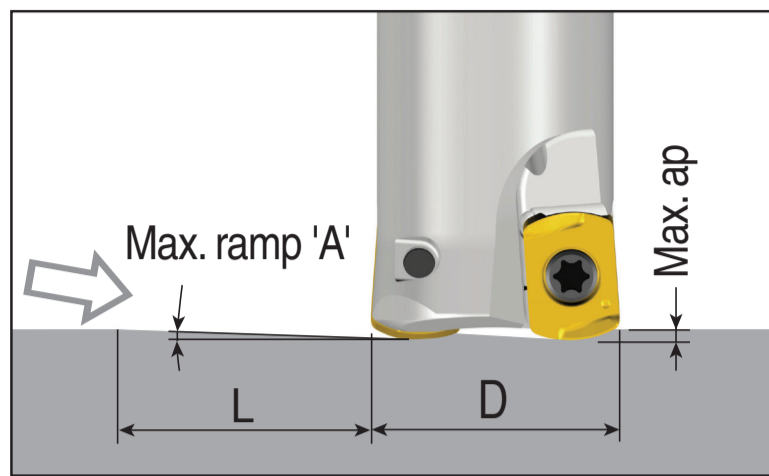

Helical ramping

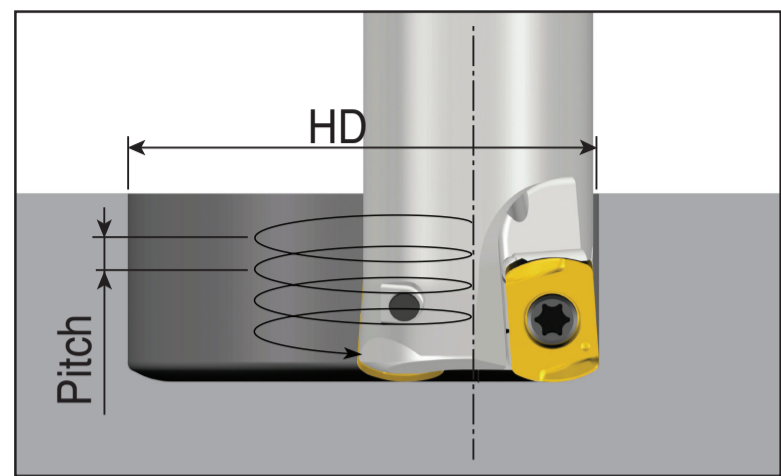

BLMP 04

(unit: mm)

Cutter dia.(D)	Straight ramp down			Helical ramp down		
	Max. ramp (A°)	Max. ap	Min. length (L)	Min. dia.(HD)	Max. dia.(HD)	Max. pitch/rev.
Ø8	0.4	0.5	72	12.6		0.1
					16	0.1
Ø10	0.6	0.5	44	16.6		0.2
					20	0.2
Ø11	0.7	0.5	38	18.6		0.2
					22	0.3
Ø12	1.0	0.5	29	20.6		0.4
					24	0.4
Ø13	1.1	0.5	25	22.6		0.5
					26	0.5
Ø16	1.0	0.5	29	28.6		0.5
					32	0.5
Ø17	1.1	0.5	26	30.6		0.5
					34	0.5
Ø20	1.0	0.5	27	36.6		0.5
					40	0.5
Ø21	0.7	0.5	38	38.6		0.5
					42	0.5
Ø25	0.7	0.5	38	46.6		0.5
					50	0.5
Ø32	0.6	0.5	48	60.6		0.5
					64	0.5

Programming technical data

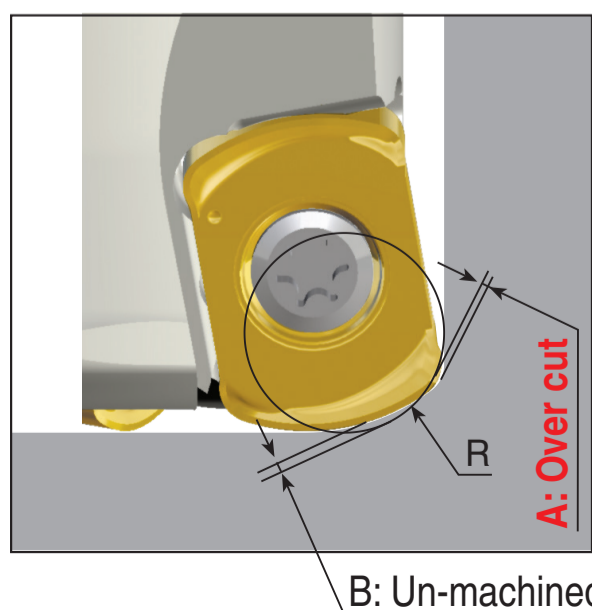

	R Program	A Over cut	B Un-machined
BLMP 04	0.8	0.00	0.28
	0.9	0.00	0.25
	1.0	0.08	0.22

: Recommended program 'R'