

Ramping Data

Straight ramping

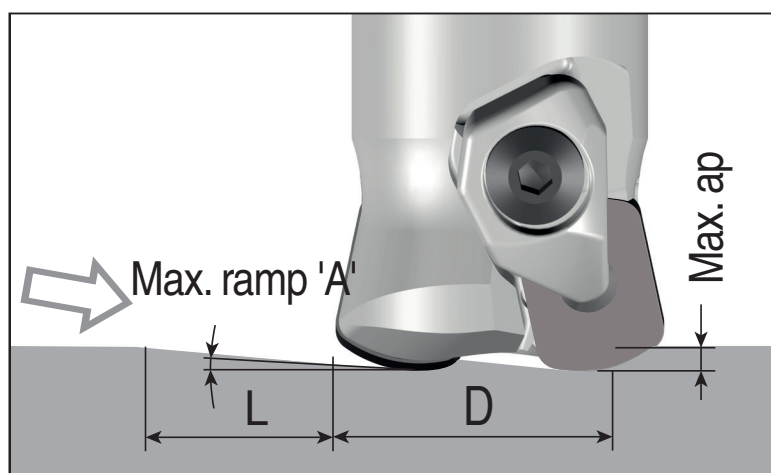

Helical ramping

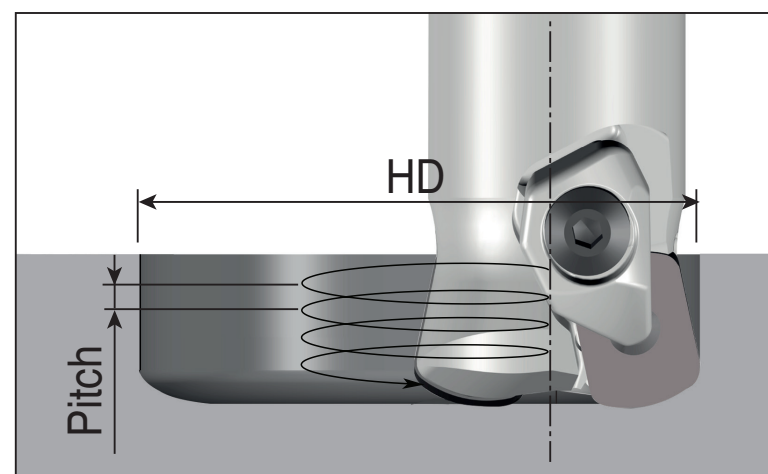

BNGX 06

(unit: mm)

Cutter dia. (D)	Straight ramp down			Helical ramp down		
	Max. ramp (A°)	Max. ap	Min. length (L)	Min. dia. (HD)	Max. dia. (HD)	Max. pitch/rev.
Ø16	0.5	1.0	115	25.6		0.2
					32	0.4
Ø20	0.5	1.0	115	33.4		0.3
					40	0.5
Ø25	0.4	1.0	144	43.4		0.4
					50	0.5
Ø32	0.3	1.0	191	57.3		0.4
					64	0.6

Programming technical data

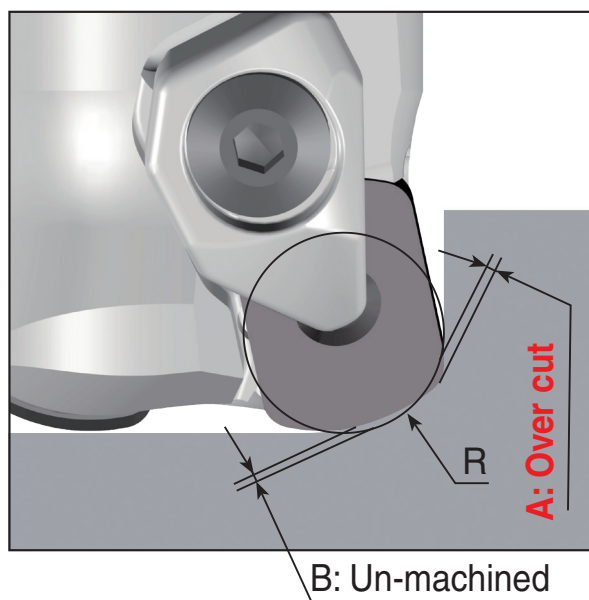

	R Program	A Over cut	B Un-machined
BNGX 06	1.5	0.00	0.60
	2.0	0.00	0.42
	2.5	0.10	0.27

: Recommended program 'R'