

# Ramping Data

Straight ramping

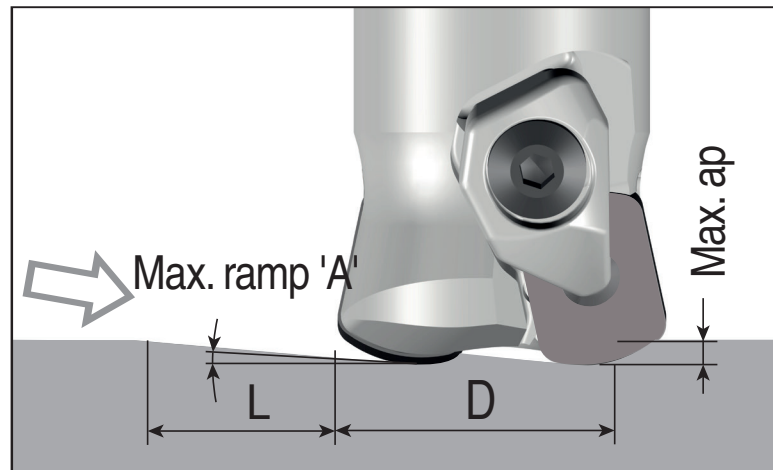

Helical ramping

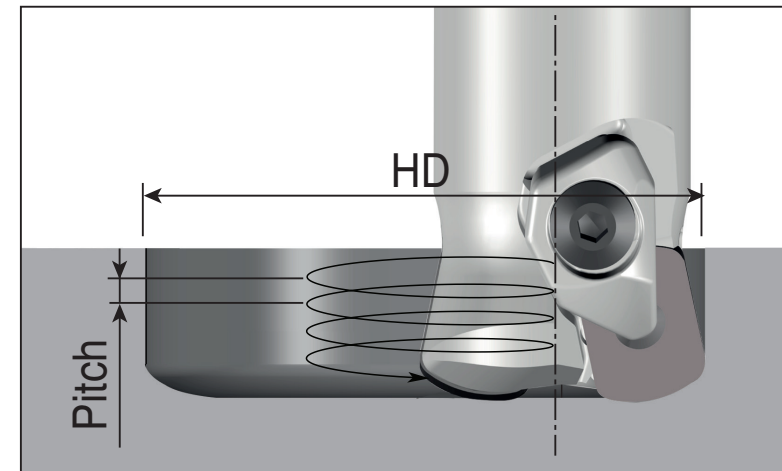

## BNGX 09

(unit: mm)

Cutter dia.(D)	Straight ramp down			Helical ramp down		
	Max. ramp (A°)	Max. ap	Min. length (L)	Min. dia.(HD)	Max. dia.(HD)	Max. pitch/rev.
Ø25	1.2	1.5	55	39		0.9
					50	1.1
Ø32	0.6	1.5	132	53		0.6
					64	0.7
Ø40	0.6	1.5	143	69		0.7
					80	0.8
Ø50	0.5	1.5	156	89		0.9
					100	1.0

## Programming technical data

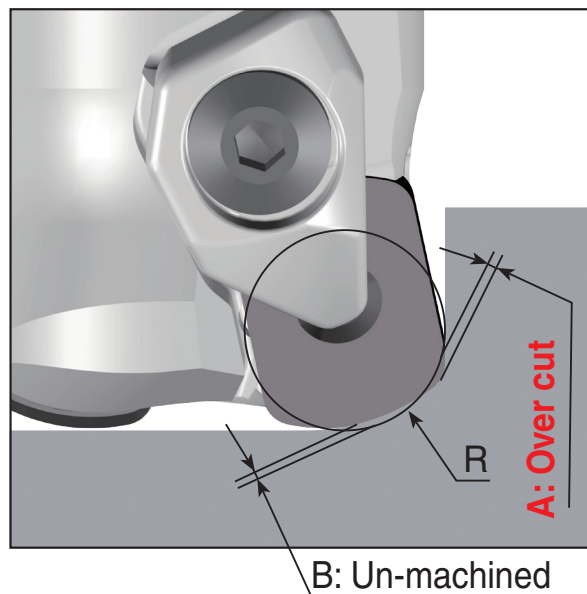

	R Program	A Over cut	B Un-machined
<b>BNGX 09</b>	3.0	0.00	0.61
	3.4	0.00	0.46
	3.5	0.01	0.43
	4.0	0.12	0.26

: Recommended program 'R'