

# Ramping Data

Straight ramping

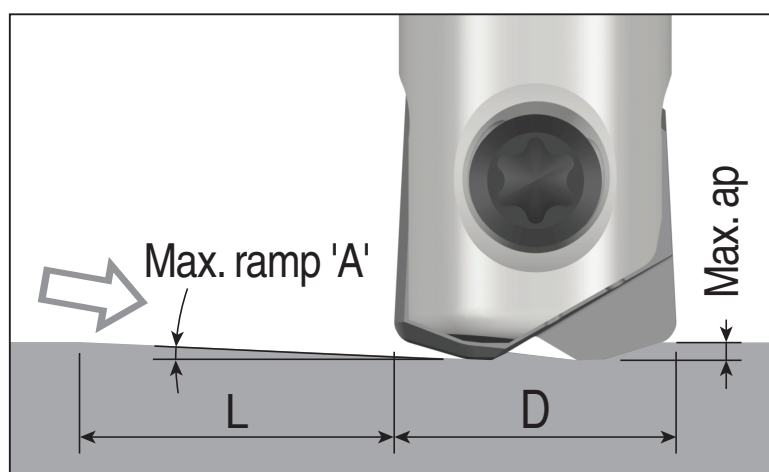

Helical ramping

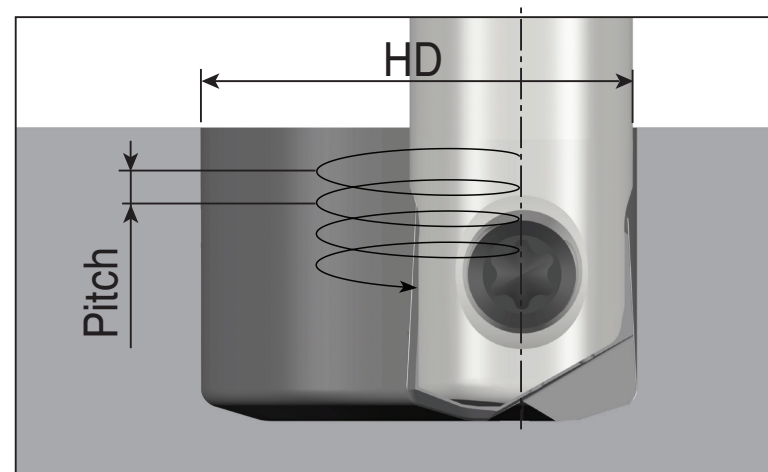

**HFN** (unit: mm)

Cutter dia.(D)	Straight ramp down			Helical ramp down		
	Max. ramp (A°)	Max. ap	Min. length (L)	Min. dia.(HD)	Max. dia.(HD)	Max. pitch/rev.
Ø6	2.0	0.3	9	9.6		0.3
					11	0.3
Ø8	2.5	0.5	11	12		0.5
					15	0.5

## Programming technical data

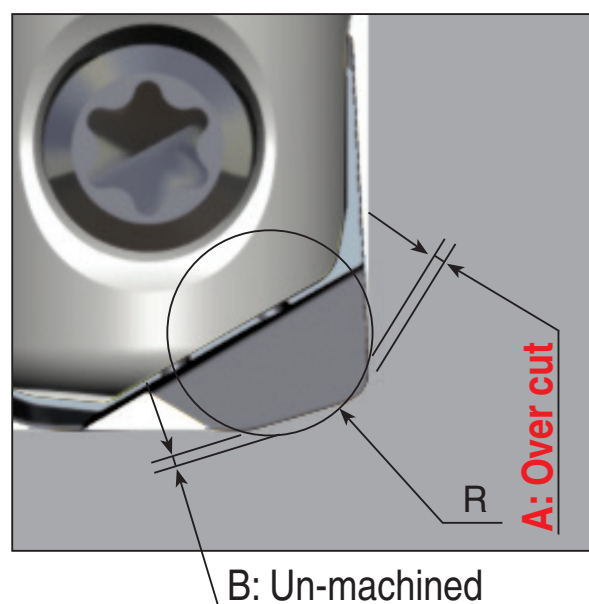

	R Program	A Over cut	B Un-machined
HFN 060	0.8	0.00	0.21
	1.0	0.03	0.16
HFN 080	0.8	0.00	0.38
	1.0	0.00	0.32
	1.2	0.02	0.27

**Yellow background**: Recommended program 'R'