

# Ramping Data

Straight ramping

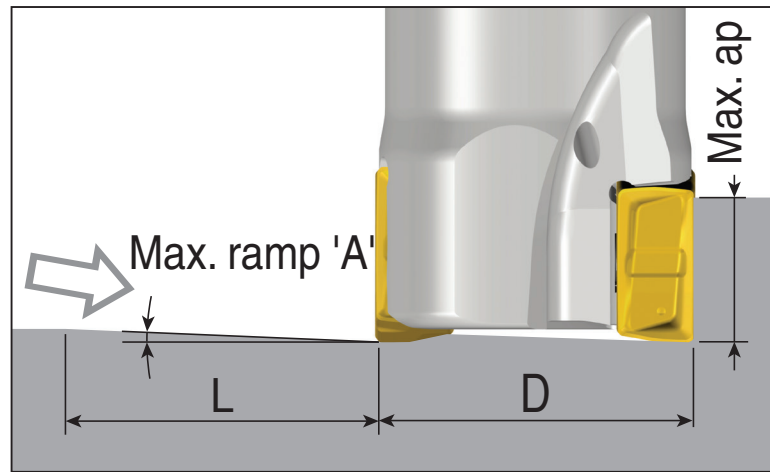

Helical ramping

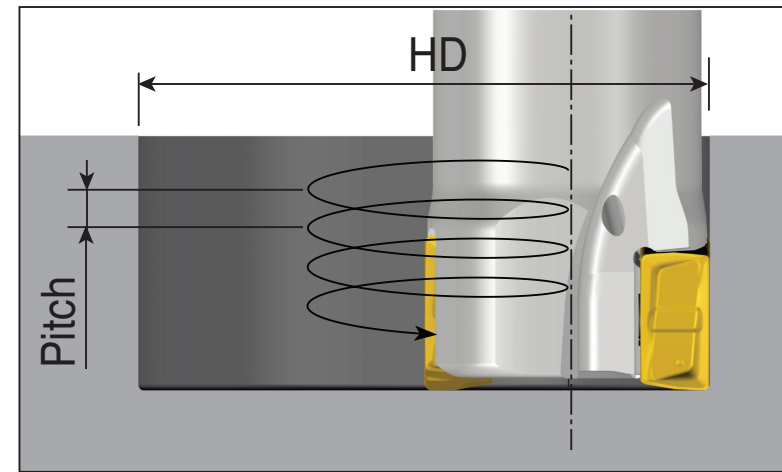

## LPK(H)U 05

(unit: mm)

Cutter dia.(D)	Straight ramp down			Helical ramp down		
	Max. ramp (A°)	Max. ap	Min. length (L)	Min. dia.(HD)	Max. dia.(HD)	Max. pitch/rev.
Ø10	1.8	4.6	142	16.8		0.6
					20	0.9
Ø11	1.6	4.6	160	18.8		0.6
					22	0.8
Ø12	1.5	4.6	176	20.8		0.6
					24	0.8
Ø13	1.3	4.6	195	22.8		0.6
					26	0.8
Ø16	1.0	4.6	251	28.8		0.6
					32	0.8
Ø20	0.8	4.6	330	36.8		0.6
					40	0.7
Ø25	0.6	4.6	439	46.8		0.6
					50	0.7
Ø32	0.4	4.6	586	60.8		0.6
					64	0.7