

Ramping Data

Straight ramping

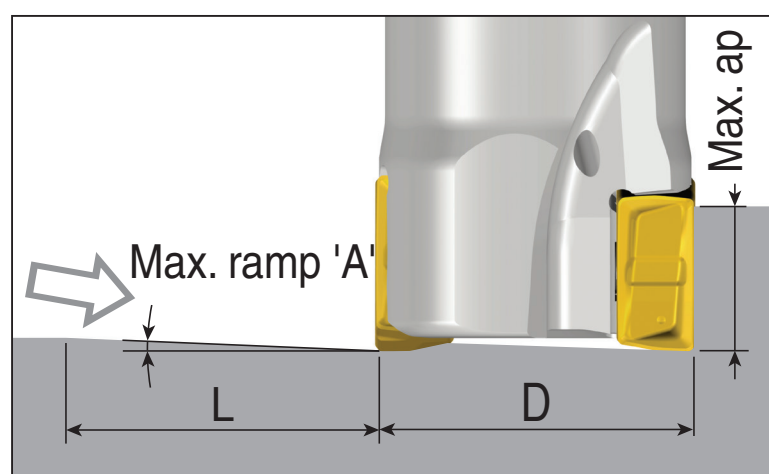

Helical ramping

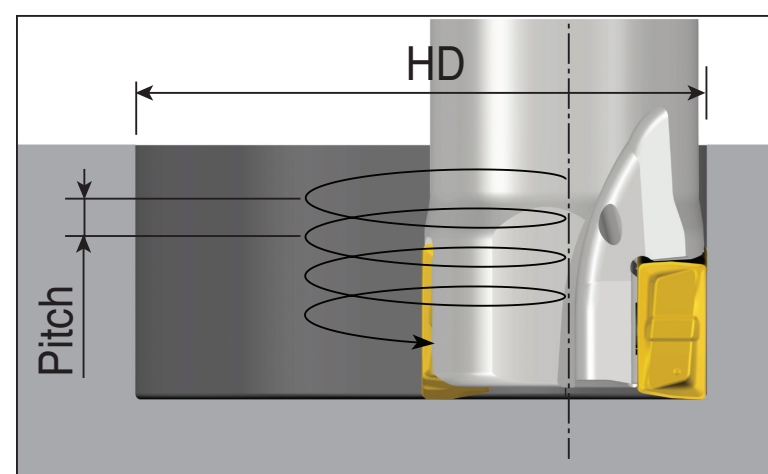

LPK(H)U 09

(unit: mm)

Cutter dia.(D)	Straight ramp down			Helical ramp down		
	Max. ramp (A°)	Max. ap	Min. length (L)	Min. dia.(HD)	Max. dia.(HD)	Max. pitch/rev.
Ø20	1.4	8.3	328	33		1.0
					40	1.5
Ø25	1.1	8.3	432	43		1.0
					50	1.5
Ø32	0.8	8.3	594	57		1.1
					64	1.4
Ø40	0.6	8.3	793	73		1.0
					80	1.3
Ø50	0.4	8.3	1057	93		1.0
					100	1.2
Ø63	0.3	8.3	1359	119		1.0
					126	1.2