

Ramping Data

Straight ramping

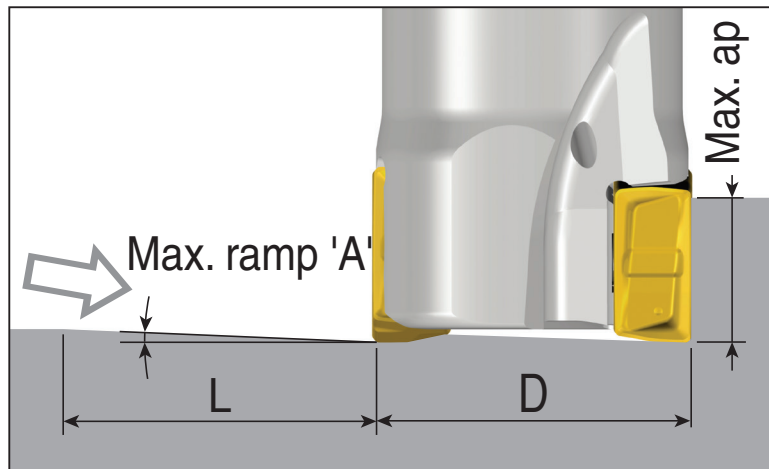

Helical ramping

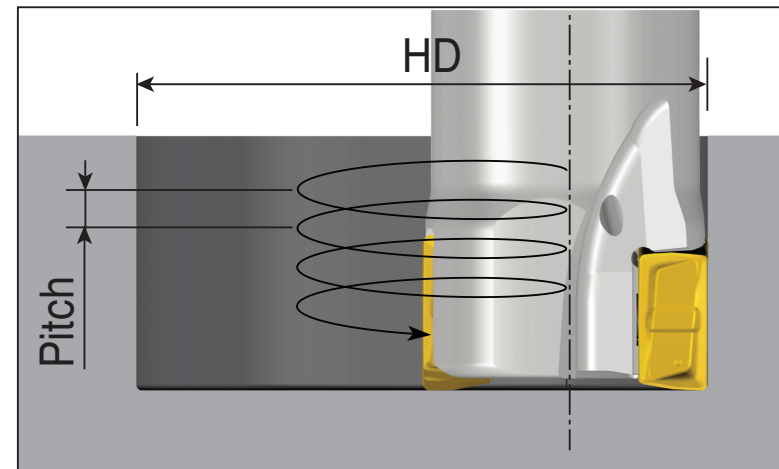

LPKU 14

(unit: mm)

Cutter dia.(D)	Straight ramp down			Helical ramp down		
	Max. ramp (A°)	Max. ap	Min. length (L)	Min. dia.(HD)	Max. dia.(HD)	Max. pitch/rev.
Ø40	0.9	12.5	754	69		1.5
					80	2.0
Ø50	0.7	12.5	1023	89		1.5
					100	1.9
Ø63	0.5	12.5	1302	115		1.5
					126	1.9
Ø80	0.4	12.5	1790	149		1.5
					160	1.7
Ø100	0.3	12.5	2387	189		1.4
					200	1.6
Ø125	0.2	12.5	2865	239		1.5
					250	1.7
Ø160	0.2	12.5	3581	309		1.6
					320	1.7
Ø200	0.1	12.5	4775	389		1.5
					400	1.6