

# Ramping Data

Straight ramping

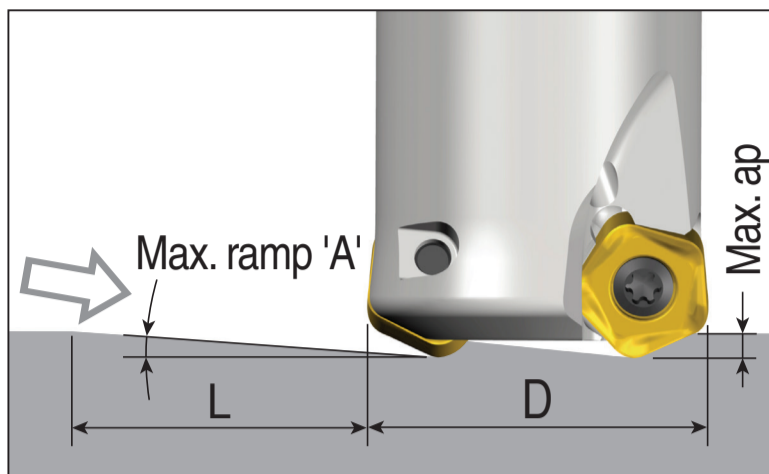

Helical ramping

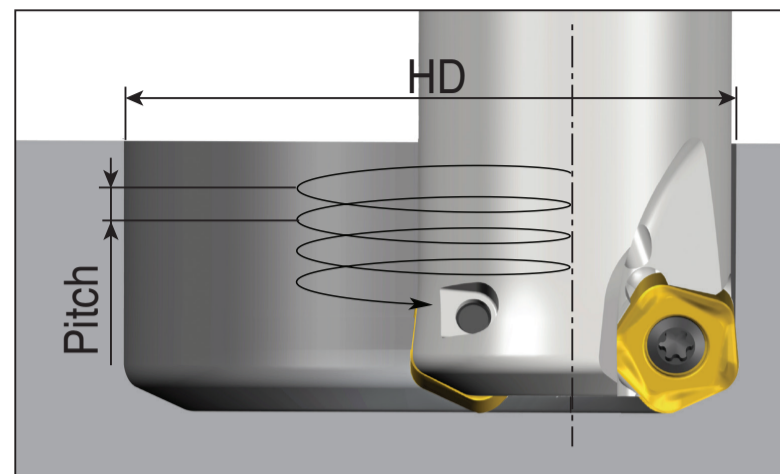

## PTKU 05

(unit: mm)

Cutter dia.(D)	Straight ramp down			Helical ramp down		
	Max. ramp (A°)	Max. ap	Min. length (L)	Min. dia.(HD)	Max. dia.(HD)	Max. pitch/rev.
Ø20	1.3	1.5	66	33		0.7
					40	0.9
Ø25	1.1	1.5	78	43		0.8
					50	1.0
Ø26	1.0	1.5	86	45		0.8
					52	0.9
Ø32	1.0	1.5	86	57		1.0
					64	1.1
Ø33	1.0	1.5	86	59		1.0
					66	1.2
Ø40	0.8	1.5	101	73		1.1
					80	1.2
Ø50	0.7	1.5	123	93		1.1
					100	1.2
Ø52	0.7	1.5	123	97		1.2
					104	1.3
Ø63	0.6	1.5	132	119		1.3
					126	1.4
Ø66	0.6	1.5	143	125		1.3
					132	1.4

## Programming technical data

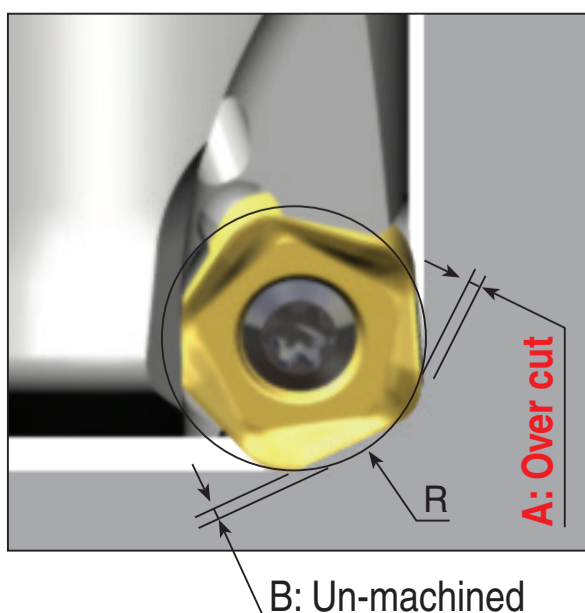

	R Program	A Over cut	B Un-machined
PTKU 05	2.5	0.00	0.83
	2.7	0.00	0.76
	3.0	0.04	0.66

: Recommended program 'R'