

Ramping Data

Straight ramping

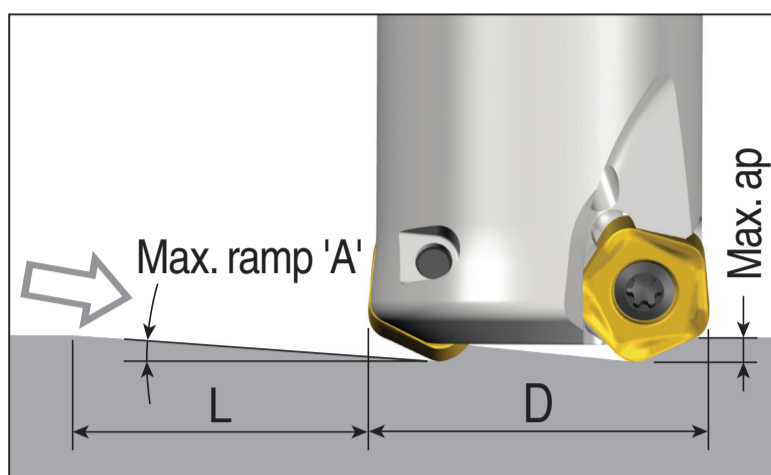

Helical ramping

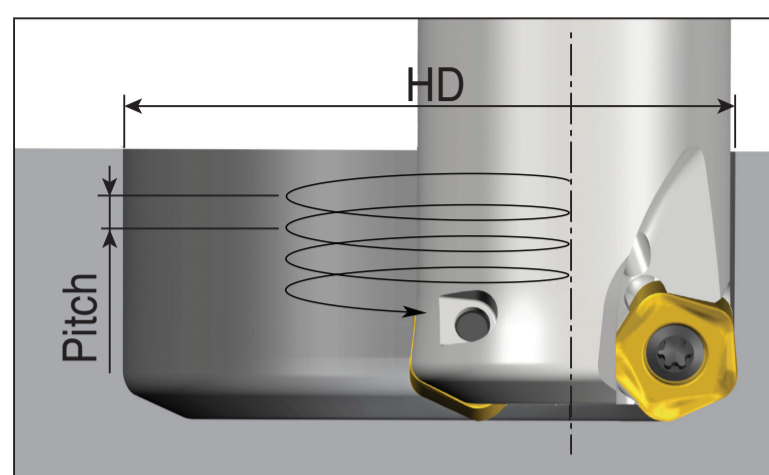

PTKU 10

(unit: mm)

Cutter dia.(D)	Straight ramp down			Helical ramp down		
	Max. ramp (A°)	Max. ap	Min. length (L)	Min. dia.(HD)	Max. dia.(HD)	Max. pitch/rev.
Ø40	1.5	3.0	111	63		1.7
					80	2.2
Ø50	1.9	3.0	88	83		2.8
					100	3.0
Ø63	1.7	3.0	101	109		3.0
					126	3.0
Ø66	2.2	3.0	78	115		3.0
					132	3.0
Ø80	1.5	3.0	115	143		3.0
					160	3.0
Ø100	1.1	3.0	150	183		3.0
					200	3.0
Ø125	0.8	3.0	202	233		3.0
					250	3.0
Ø160	0.6	3.0	265	303		3.0
					320	3.0
Ø200	0.5	3.0	344	383		3.0
					400	3.0

Programming technical data

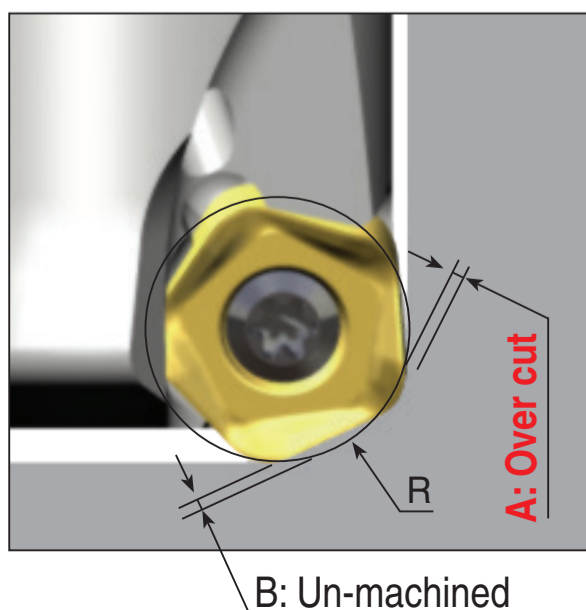

	R Program	A Over cut	B Un-machined
PTKU 10	5.5	0.00	1.45
	6.0	0.09	1.28
	6.5	0.21	1.11

Yellow background: Recommended program 'R'